

## Measurement and Geometry

93. One millimeter is—

- A  $\frac{1}{1000}$  of a meter.
- B  $\frac{1}{100}$  of a meter.
- C 100 meters.
- D 1000 meters.

M00276

94. A boy is two meters tall. About how tall is the boy in feet (ft) and inches (in.)? (1 meter  $\approx$  39 inches.)

- A 5 ft 0 in.
- B 5 ft 6 in.
- C 6 ft 0 in.
- D 6 ft 6 in.

M02044

## Measurement and Geometry

95. Juanita exercised for one hour. How many seconds did Juanita exercise?

- A 60
- B 120
- C 360
- D 3,600

M03074

96. If Jill is driving at 65 miles per hour, what is her approximate speed in kilometers per hour? (1 mile  $\approx$  1.6 kilometers)

- A 16
- B 41
- C 104
- D 173

M13251

97. The actual width ( $w$ ) of a rectangle is 18 centimeters (cm). Use the scale drawing of the rectangle to find the actual length ( $l$ ).

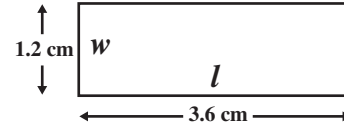

- A 6 cm
- B 24 cm
- C 36 cm
- D 54 cm

M02087

*Measurement and Geometry*

98. The scale drawing of the basketball court shown below is drawn using a scale of 1 inch (in.) = 24 feet (ft).

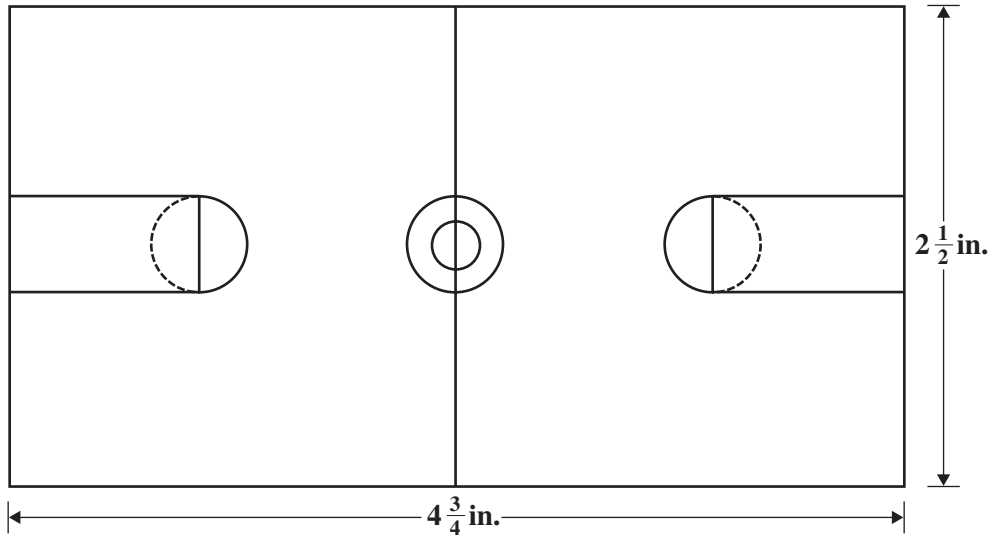

What is the length, in feet, of the basketball court?

- A 90 ft
- B 104 ft
- C 114 ft
- D 120 ft

M02233

## Measurement and Geometry

99. Javier is using a ruler and a map to measure the distance from Henley to Sailport.

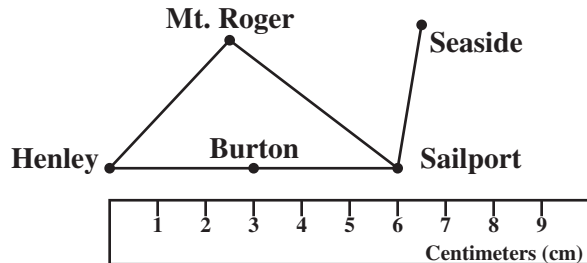

The actual distance from Henley to Sailport is 120 kilometers (km). What scale was used to create the map?

- A 1 cm = 6 km
- B 1 cm = 12 km
- C 1 cm = 15 km
- D 1 cm = 20 km

M21169

100. Sixty miles per hour is the same rate as which of the following?

- A 1 mile per minute
- B 1 mile per second
- C 6 miles per minute
- D 360 miles per second

M02473

101. Beverly ran six miles at the speed of four miles per hour. How long did it take her to run that distance?

- A  $\frac{2}{3}$  hr
- B  $1\frac{1}{2}$  hrs
- C 4 hrs
- D 6 hrs

M02041

102. Marcus can type about 42 words per minute. If he types at this rate for 30 minutes without stopping, about how many words will he type?

- A 1260
- B 2100
- C 2520
- D 4200

M21029

103. A landscaper estimates that landscaping a new park will take 1 person 48 hours. If 4 people work on the job and they each work 6-hour days, how many days are needed to complete the job?

- A 2
- B 4
- C 6
- D 8

M11541

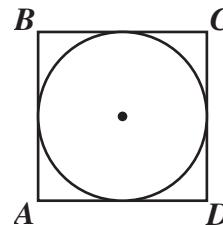

104. In the figure above, the radius of the inscribed circle is 6 inches (in.). What is the perimeter of square  $ABCD$  ?

- A  $12\pi$  in.
- B  $36\pi$  in.
- C 24 in.
- D 48 in.

M02236

*Measurement and Geometry*

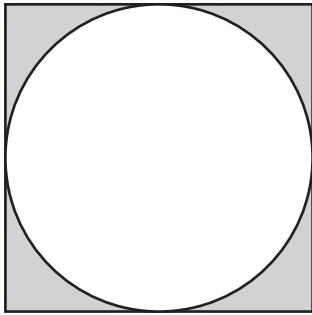

10 feet

105. The largest possible circle is to be cut from a 10-foot square board. What will be the approximate area, in square feet, of the remaining board (shaded region)? ( $A = \pi r^2$  and  $\pi \approx 3.14$ )

- A 20
- B 30
- C 50
- D 80

M00404

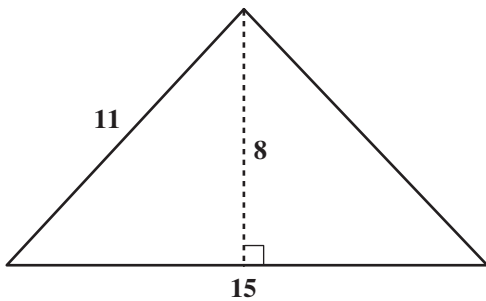

106. What is the area of the triangle shown above?

- A 44 square units
- B 60 square units
- C 88 square units
- D 120 square units

M00101

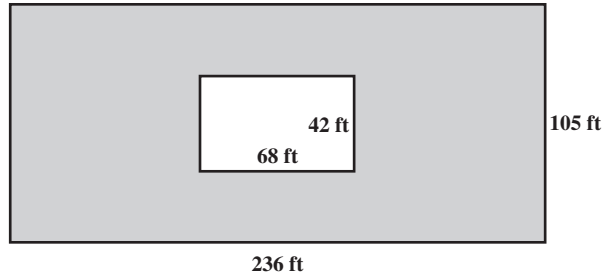

107. A rectangular pool 42 feet by 68 feet is on a rectangular lot 105 feet by 236 feet. The rest of the lot is grass. Approximately how many square feet is grass?

- A 2,100
- B 2,800
- C 21,000
- D 28,000

M00311



108. What is the volume of the shoebox shown above in cubic inches ( $\text{in.}^3$ )?

- A 29
- B 75
- C 510
- D 675

M02629

*Measurement and Geometry*

109. What is the area, in square units, of trapezoid  $QRST$  shown below?

$$\left[ A = \frac{1}{2}h(b_1 + b_2) \right]$$

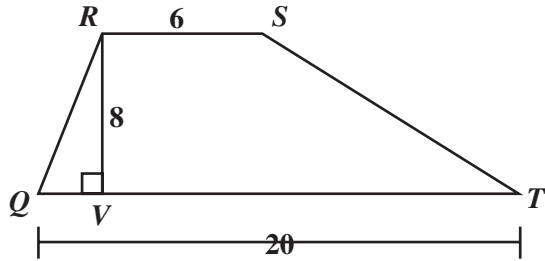

- A 68
- B 104
- C 208
- D 960

M12087

110. One-inch cubes are stacked as shown in the drawing below.

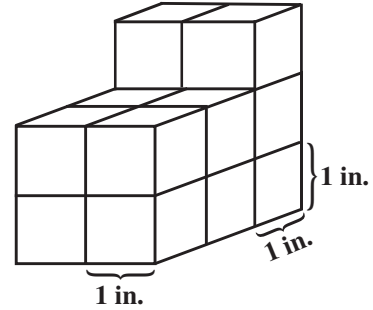

What is the total surface area?

- A  $19 \text{ in.}^2$
- B  $29 \text{ in.}^2$
- C  $32 \text{ in.}^2$
- D  $38 \text{ in.}^2$

M02812

*Measurement and Geometry*

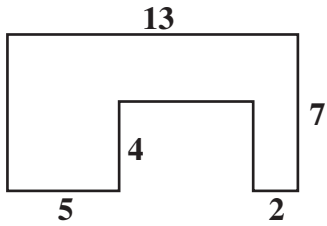

111. In the figure shown above, all the corners form right angles. What is the area of the figure in square units?
- A 67
  - B 73
  - C 78
  - D 91

M00318

112. What is the area of the shaded region in the figure shown below?

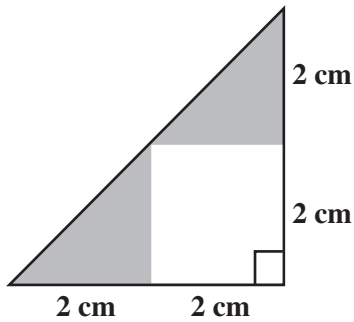

- A  $4 \text{ cm}^2$
- B  $6 \text{ cm}^2$
- C  $8 \text{ cm}^2$
- D  $16 \text{ cm}^2$

M02814

113. A right triangle is removed from a rectangle as shown in the figure below. Find the area of the remaining part of the rectangle.

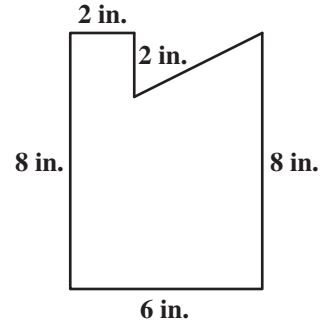

- A  $40 \text{ in.}^2$
- B  $44 \text{ in.}^2$
- C  $48 \text{ in.}^2$
- D  $52 \text{ in.}^2$

M02093

## Measurement and Geometry

114. In the figure below, every angle is a right angle.

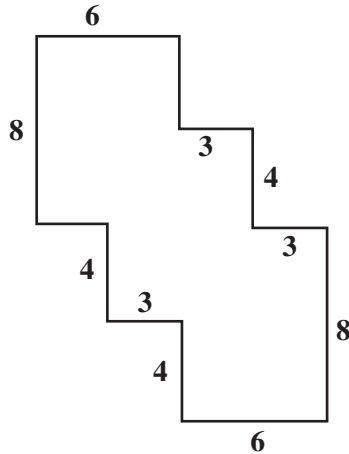

What is the area, in square units, of the figure?

- A 96
- B 108
- C 120
- D 144

M10790

115. The short stairway shown below is made of solid concrete. The height and width of each step is 10 inches (in.). The length is 20 inches.

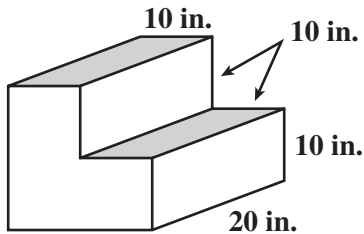

What is the volume, in cubic inches, of the concrete used to create this stairway?

- A 3000
- B 4000
- C 6000
- D 8000

M02990

Circle  $x$

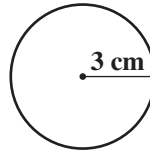

Circle  $y$

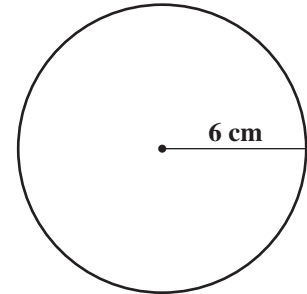

116. The two circles shown above have radii of 3 cm and 6 cm.

What is  $\frac{\text{Circumference of Circle } x}{\text{Circumference of Circle } y}$ ?

- A  $\frac{1}{4}$
- B  $\frac{1}{2}$
- C  $\frac{\pi}{4}$
- D  $\frac{\pi}{2}$

M02217



## Measurement and Geometry

117. Bonni has two similar rectangular boxes. The dimensions of box 1 are twice those of box 2. How many times greater is the volume of box 1 than the volume of box 2?

A 3  
B 6  
C 8  
D 9

M21061

118. Gina is painting the rectangular tool chest shown in the diagram below.

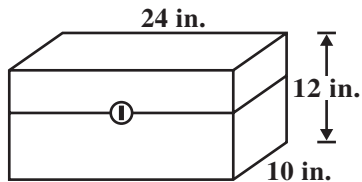

If Gina paints only the outside of the tool chest, what is the total surface area, in square inches ( $\text{in.}^2$ ), she will paint?

A 368  
B 648  
C 1296  
D 2880

M20643

119. The width of the rectangle shown below is 6 inches (in.). The length is 2 feet (ft).

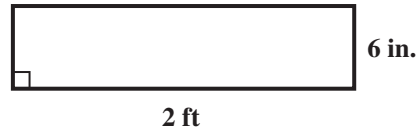

What is the area of the rectangle in square inches?

A 12  
B 16  
C 60  
D 144

M03243

120. One cubic inch is approximately equal to 16.38 cubic centimeters. Approximately how many cubic centimeters are there in 3 cubic inches?

A 5.46  
B 13.38  
C 19.38  
D 49.14

M02700

121. A rectangular field is 363 feet long and 240 feet wide. How many acres is the field? (1 acre = 43,560 square feet)

A 2  
B 3  
C 4  
D 5

M13918

*Measurement and Geometry*

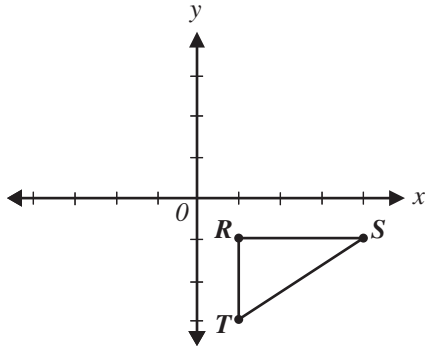

122. Which of the following triangles  $R'S'T'$  is the image of triangle  $RST$  that results from reflecting triangle  $RST$  across the  $y$ -axis?

A

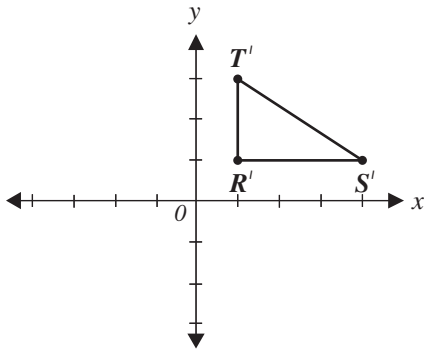

C

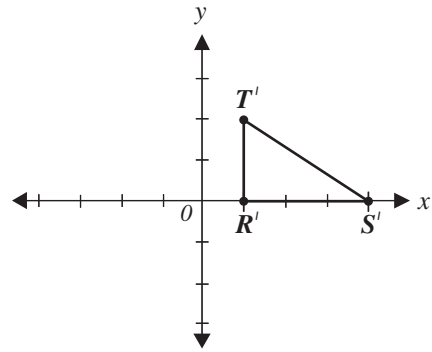

B

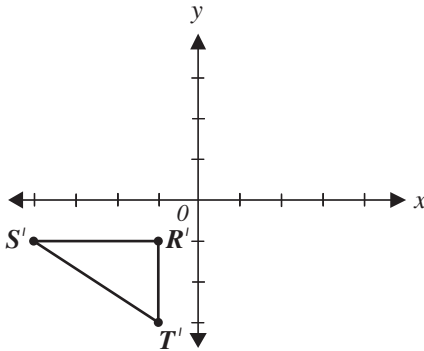

D

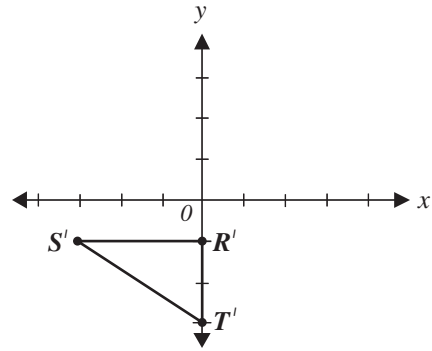

M02861

## Measurement and Geometry

123. The points  $(1, 1)$ ,  $(2, 3)$ ,  $(4, 3)$ , and  $(5, 1)$  are the vertices of a polygon. What type of polygon is formed by these points?

- A Triangle
- B Trapezoid
- C Parallelogram
- D Pentagon

M02718

124. The graph of rectangle  $ABCD$  is shown below.

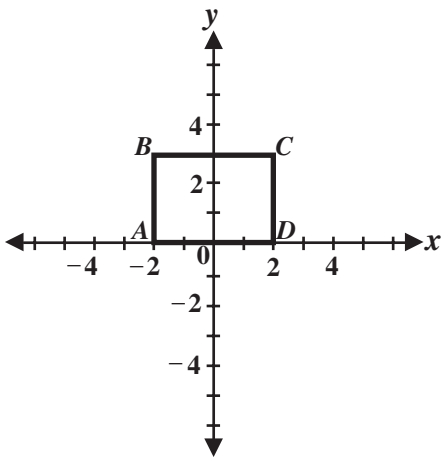

What is the area, in square units, of rectangle  $ABCD$ ?

- A 6
- B 10
- C 12
- D 14

M03136

125. A clothing company created the following diagram for a vest.

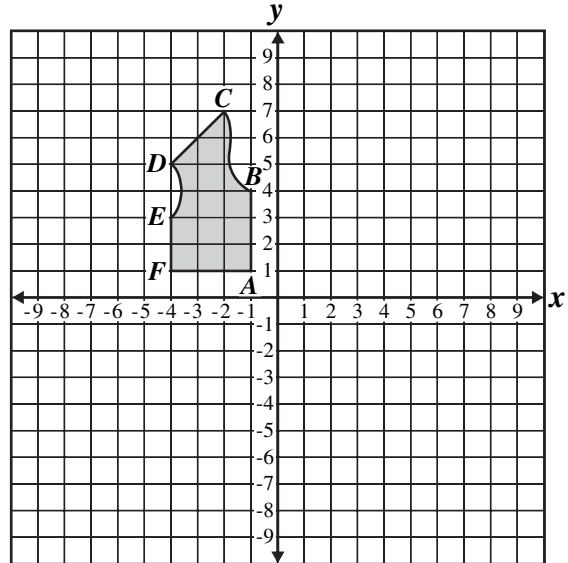

To show the other side of the vest, the company will reflect the drawing across the  $y$ -axis. What will be the coordinates of  $C$  after the reflection?

- A  $(2, 7)$
- B  $(7, 2)$
- C  $(-2, -7)$
- D  $(-2, 7)$

M10640

*Measurement and Geometry*

126. What is the value of  $x$  in the right triangle shown below?

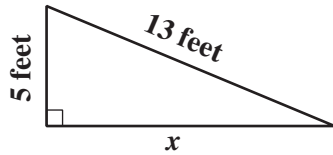

- A 8 feet
- B 12 feet
- C 18 feet
- D 23 feet

M03181

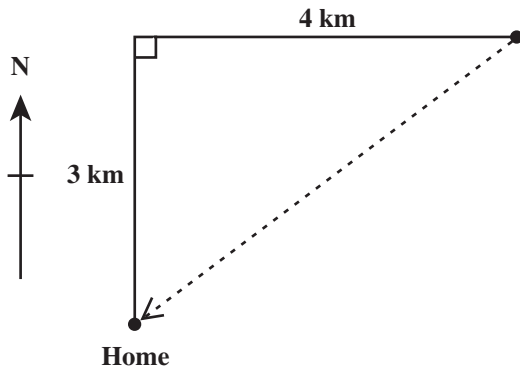

127. The club members hiked 3 kilometers north and 4 kilometers east, but then went directly home as shown by the dotted line. How far did they travel to get home?

- A 4 km
- B 5 km
- C 6 km
- D 7 km

M00120

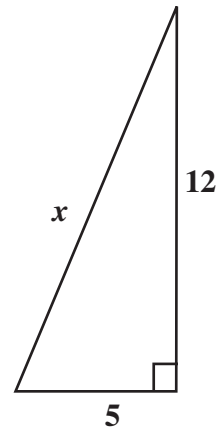

128. What is the value of  $x$  in the triangle shown above?

- A 11
- B 13
- C 17
- D 169

M02446

*Measurement and Geometry*

129. In the drawing below, the figure formed by the squares with sides that are labeled  $x$ ,  $y$ , and  $z$  is a right triangle.

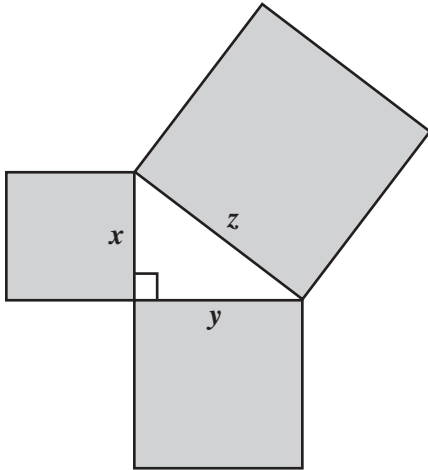

Which equation is true for all values of  $x$ ,  $y$ , and  $z$ ?

- A  $x + y = z$
- B  $x^2 + y^2 = z^2$
- C  $x^2 \cdot y^2 = z^2$
- D  $\frac{1}{2}xy = z$

M25150

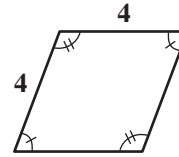

130. Which figure is congruent to the figure shown above?

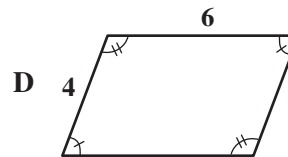
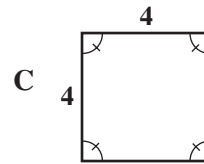
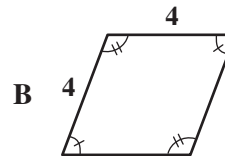
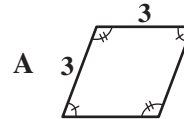

M00020

*Measurement and Geometry*

131. In the diagram below, hexagon  $LMNPQR$  is congruent to hexagon  $STUVWX$ .

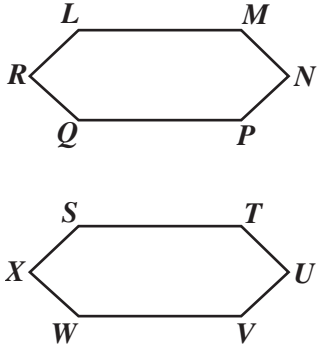

Which side is the same length as  $\overline{MN}$  ?

- A  $\overline{NP}$
- B  $\overline{TU}$
- C  $\overline{UV}$
- D  $\overline{WX}$

M13069